

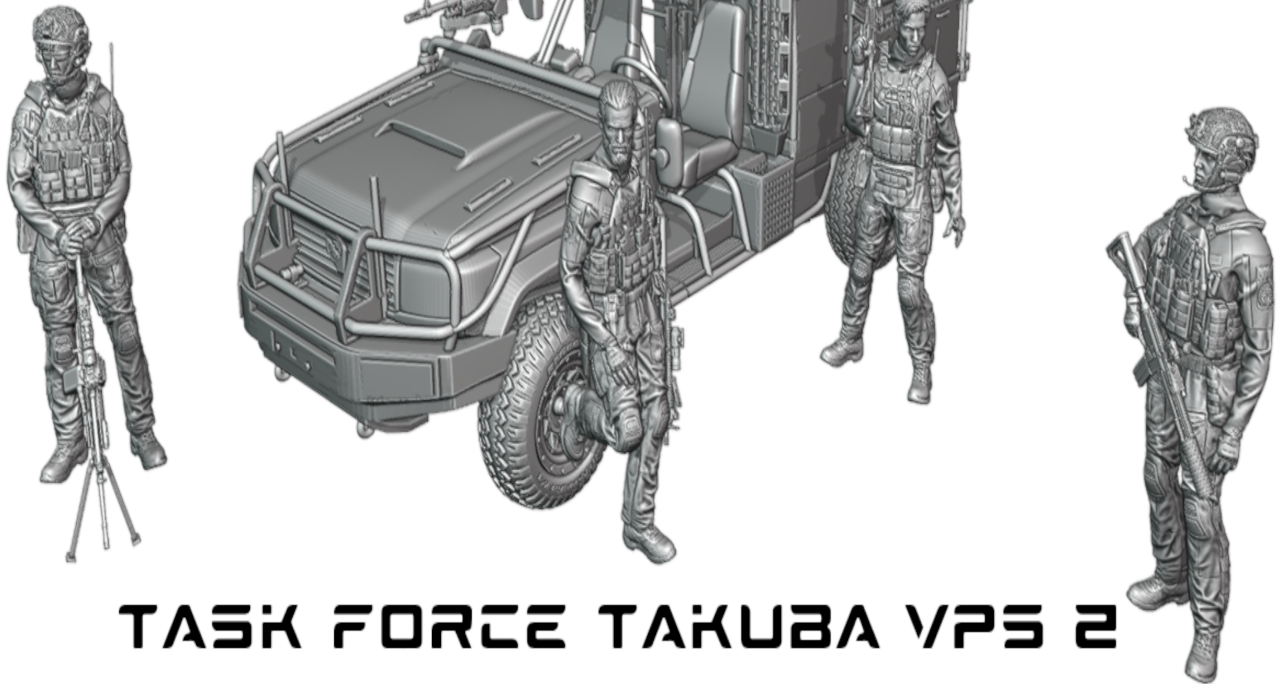

BLACKSNAKE MODEL

SCULPTING IMAGINATION BEYOND LIMITS



TASK FORCE TAKUBA VPS 2

History of creation

is based on a Toyota Land Cruiser with a 6-cylinder 4,164cc diesel engine. 300 units among the 500 ordered have already been delivered to the French army.

In addition to the T4 Masstech, Technamm has sold 50 Masstech Recamp pickup trucks equipped with a tubular support structure for a machine gun, also based on Toyota. The Masstech Recamp is delivered to units that are deployed in the G5 Sahel region, in the sub-Saharan zone, where they operate against Islamist terrorist militias. Technamm has already delivered 30 of the 50 Masstech Recamp ordered by the French army.

Technamm has developed a 6x6 version of its Masstech T4: the Masstech T6. The company is currently developing a Masstech VPS / 2-Fox for special forces, based on the T4.

The company also markets a large SUV or armored pickup, still based on Toyota: the Technamm Baroud 3.5T.

Last vehicle to be mentioned, the Fennec is a small 'fardier' (light transport vehicle) designed on the basis of the Suzuki Jimny. The vehicle is powered by a Renault 1.5 dci, thus easily available and inexpensive. The Fennec equipped with a tubular protective superstructure, jerrycan brackets and a machine gun. The targeted market is obviously the special forces. When you see all that is proposed in the field of special forces vehicles at Eurosatory, one can only admire a British captain of genius: Captain David Stirling, creator of the Special Air Service - the SAS - in North Africa on July 1, 1941; the vehicles have evolved but Stirling's philosophy of action remains extraordinarily up-to-date!

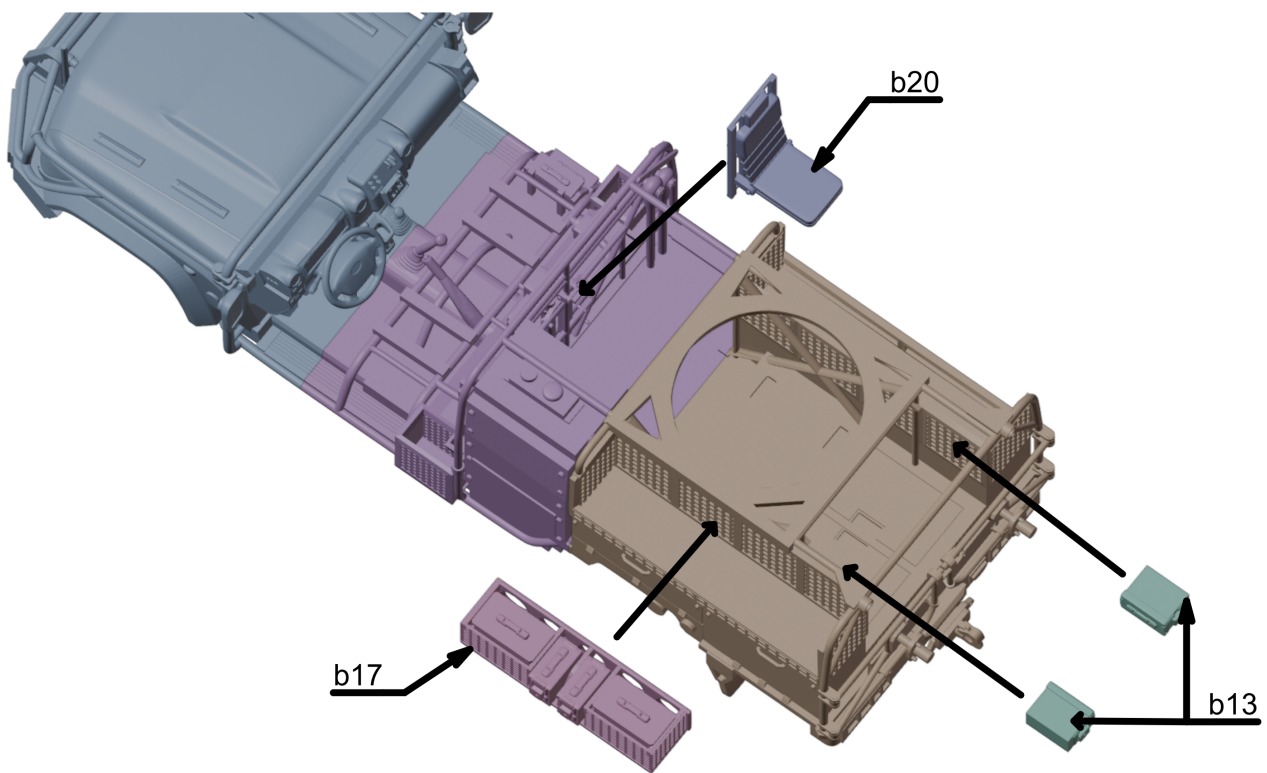

necessary
details

b1x1 **b17x1**

b2x1 **b13x1**

b3x1 **b20x1**

b9x1

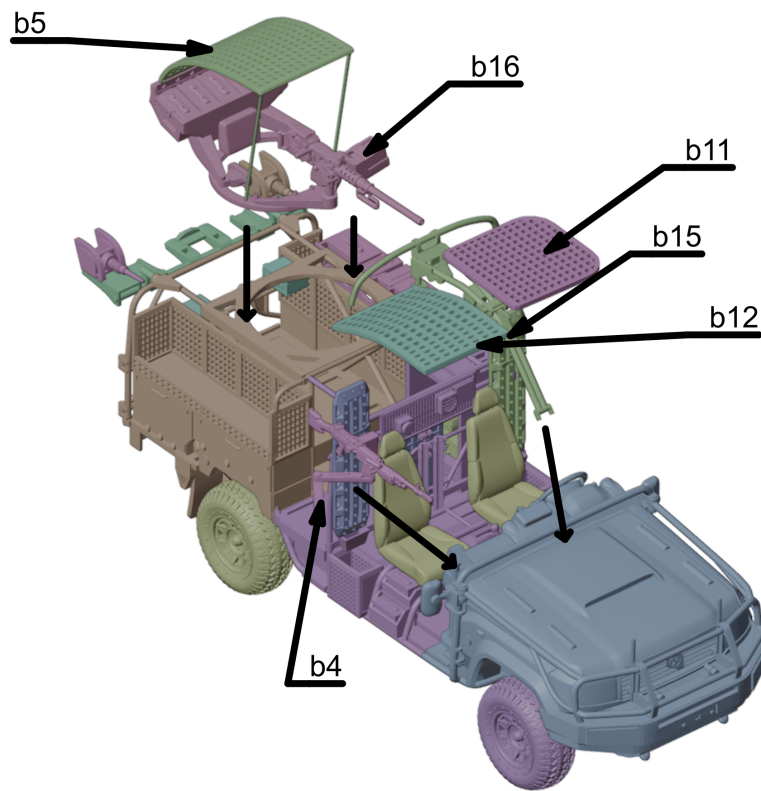
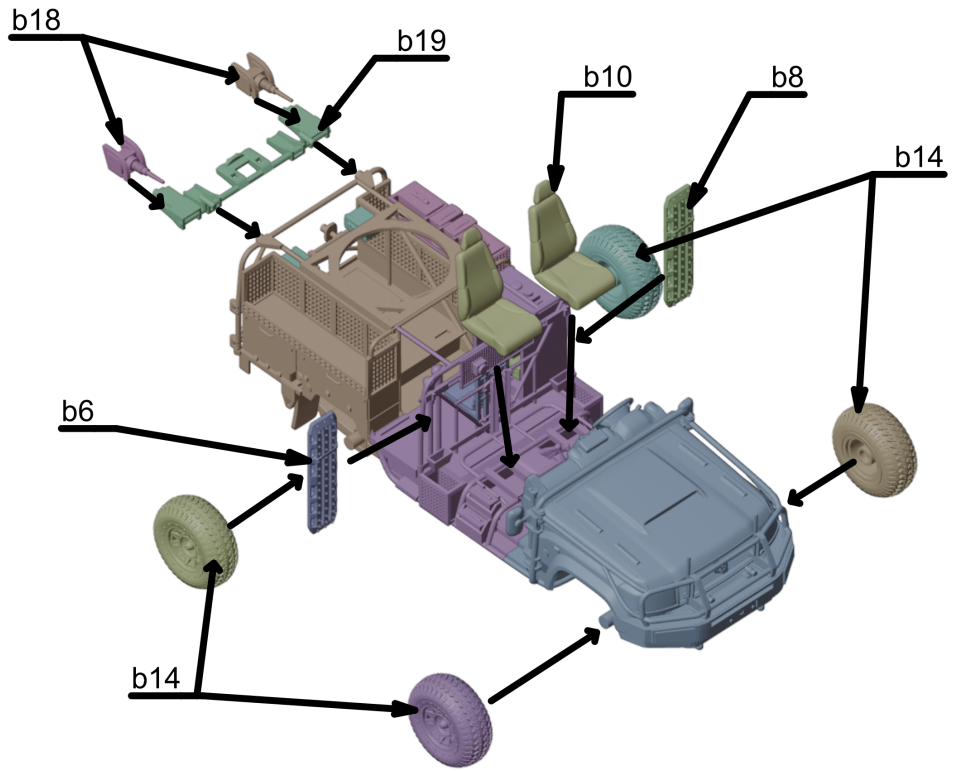

necessary
details

- | | | |
|-------------|--------------|--------------|
| b4x1 | b10x1 | b15x1 |
| b5x1 | b11x1 | b16x1 |
| b6x1 | b12x1 | b18x1 |
| b8x1 | b14x1 | b19x1 |